

# *Farm dams in Western Australia*

---



Department of  
Agriculture



# Farm dams in Western Australia

---

By David Stanton

March 2005

Bulletin 4609  
ISSN 1448-0352

## Contents

---

<i>What is a farm dam?</i> .....	4
<i>How farm dams work</i> .....	5
<i>Types of dams</i> .....	6
<i>Planning considerations</i> .....	10
<i>Quotation from Earthmoving Contractors</i> .....	13
<i>Dam failures and problems</i> .....	14
<i>Design and specifications of a conventional excavated tank</i> .....	15
<i>Construction</i> .....	16
<i>Maintenance</i> .....	20
<i>Legal aspects</i> .....	20
<i>Impacts and risks</i> .....	21
<i>Glossary</i> .....	23

## Acknowledgements

JP Clement for legal aspects; Neil Coles for assistance with editing; Donald Bodeker for assistance with diagrams; Mark Pridham and Ian Laing for photographs.

Disclaimer: This publication is for general information only. With difficult dam sites landholders are advised to obtain a geotechnical analysis of the soil from a laboratory to determine its suitability for dam building.

## What is a farm dam?

Many rural properties in Western Australia rely on dams as very few areas have access to suitable supplies of groundwater.

Historically, most landholders have developed on-farm water supplies to meet their likely demand for years when properties receive average annual rainfall. However, with lower rainfall predicted due to climate change, there is an urgent need to improve the reliability of farm water supplies.



*Gully-wall dam on a property in the Donnybrook district.*

Farm dams are water conservation structures designed to impound water using a constructed earth barrier or embankment that has a clay core or clay blanket keyed into impervious material and an excavation on the upslope side.

A number of different structures have been developed to optimise water storage in a variety of agricultural landscapes. These structures include:

- rectangular and square excavated tanks with three or four walls;
- circular excavated tanks;
- gully-wall dams;
- flat batter dams; and
- turkey nest dams.

Different configurations of these structures are used as detention dams, double dams and excavated soaks. The most common dam is the excavated tank, but other structures can be preferred for specific uses and locations.

Where valley floors are not affected by rising watertables, gully-wall dams provide a valuable water source for horticulture.

Farm dams are used to provide long-term storage for:

- watering livestock;
- crop spraying;
- irrigation;
- domestic supply; and
- fire fighting.

Most dams are constructed to store run-off generated from rainfall events. In other cases they are built as evaporation basins, and can also be used to store pumped groundwater. Soak dams are used to store seepage water.

Farm dams are recognised as important structures for the management of problems associated with excess run-off.

They can provide short-term detention storage to:

- contain surface water above gullies and alleviate soil erosion;
- trap sediment below eroded areas; and
- control the release of run-off down slope reducing the impact of waterlogging, inundation and flooding.

## How farm dams work

### Water-holding capability

The water-holding properties of a farm dam are achieved using construction methods that provide a cover of reworked compacted clay on the base and sides. This clay blanket needs to be thick enough to provide a seal so that only small amounts of seepage are lost.

Provided dams are sited to optimise the slope of the natural catchment above them, run-off from this catchment will flow unobstructed into them. In below average rainfall years, run-off from natural catchments is reduced and may fail to replenish dams sufficiently to meet demand.

### Improved catchments

The area contributing run-off to the dam can be maximised by improving the catchment. Half-roads have a broad flat channel with clay on the base and are one of the most effective method of catchment improvement (see Figure 1).

With improved catchments, the area available to collect run-off from low rainfall events can be increased by lowering the threshold at which run-off is generated. This will increase the number of rainfall events that contribute run-off to the dam.

Improved catchments also include:

- constructed roaded catchments;
- granite outcrops;
- farm tracks or bitumen roads.

Landscape features such as breakaways, mallet hills and areas of non-dispersive heavy clays yield high volumes of run-off. If any of these features are available, they should be used to optimise the area of catchment that contributes run-off to the dam.

Ideally, livestock should not have direct access to dam water. Livestock should be watered using an outlet pipe from the dam that transfers the water to tanks and troughs. Water troughs can be monitored quickly and easily from the farm office, using a photographic monitoring technique and water level sensors that provide information for all water supplies.

The style of farm dam used should reflect the landscape and demand for water.



Half-road at Lake Grace used to improve water capture and improve reliability of farm dams.

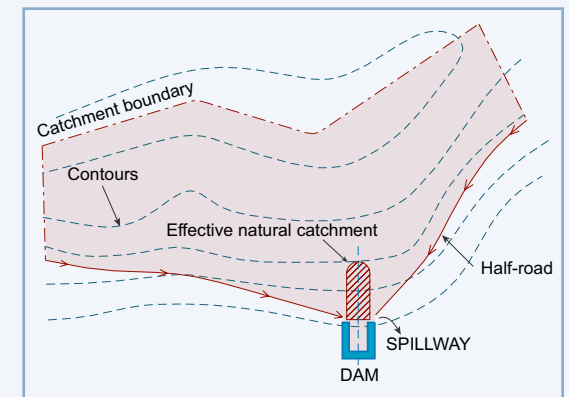

Figure 1. Half-roads optimise the area of natural catchment.

## Types of dams



Monitoring equipment sends water level data to the farm office via a radio link. The video camera allows the stock to be observed at the trough.

### Excavated tanks

Traditional excavated earth tanks are the most common type of dam used in the agricultural areas of WA (see Figure 2). The shape of these structures is usually described as a truncated prism with a rectangular plan.

Excavated tanks can be round or have three or four walls. They are constructed of clay, or at least have a clay lining that is 0.7 to 1.0 metre thick depending on the position in the dam.

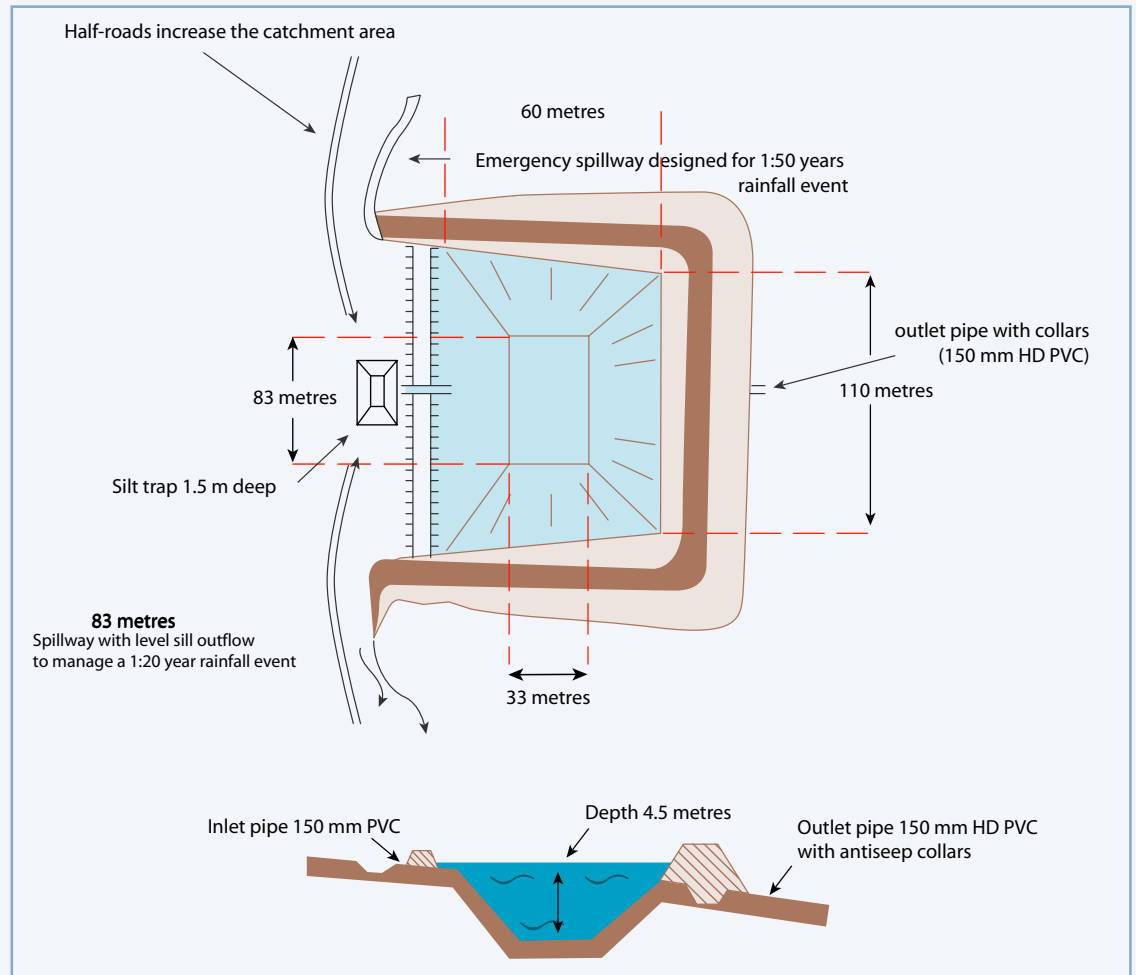

Figure 2. Plan and cross-section for a four-sided dam with inlet and outlet pipes (not to scale). Plans overcome many problems and the landholder should always insist that the contractor provides an accurate plan of the proposed farm dam.

A three-walled excavated tank has the soil from the excavation distributed onto the three walls that are raised above ground level to provide freeboard above the full supply level.

These dams are left open at ground level on the remaining uphill side to allow entry of run-off from the catchment above the dam.

To optimise capacity most landholders now build four-walled or round dams. Enclosed, four-walled or round dams are generally used on flatter sites where it is desirable to hold water above ground level. These dams rely on wing banks and piped inlets to convey water into them.

Wing banks extending from the front form a broad, shallow temporary storage in front of the dam and allow sediment load to settle, acting as a trap which is easily maintained. Storage life of these dams is usually 25 years before any major maintenance is required.

This design (see Figure 3) has the advantage of lower evaporation loss as the water is not open to the prevailing winds. The recommended batter slope is 3:1. If the slope is flatter than 4:1 evaporation losses are increased.

Round dams are the most efficient form of excavated tank because:

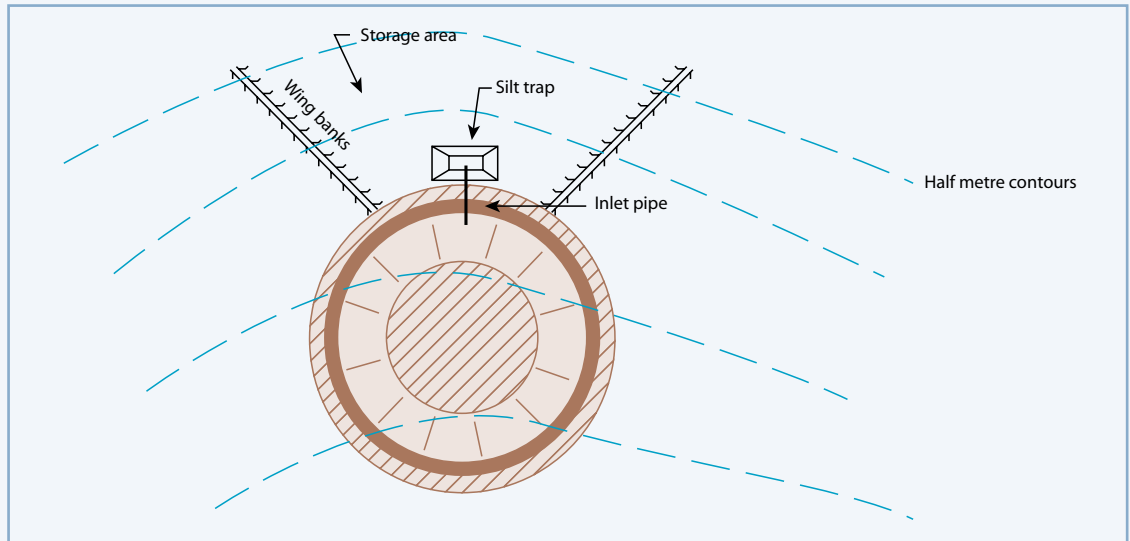

Figure 3. A circular shape is the most efficient form of excavated tank.

- during construction each bulldozer push is of equal distance from the bottom of the dam;
- large amounts of soil are not required for constructing the corners;
- side-cutting (a technique used to clean up the batters that reduces rilling on the dam walls) can be carried out efficiently;
- evaporation losses are lower than for square and rectangular dams; and
- maintenance costs are reduced as there is less sedimentation because run-off from the dam batters does not collect in the corners of the dam.

Round dams gained popularity in agricultural areas following success in pastoral areas around Kalgoorlie. Care needs to be taken to ensure that wing banks are correctly surveyed to fill the dam and provide an adequate spillway that clears the outside batter.

#### Double dams

Double dams are useful where watertables limit depth. The design reduces the impact of evaporation and is particularly effective where water is moved from a large dam to a smaller dam (see Figure 4).

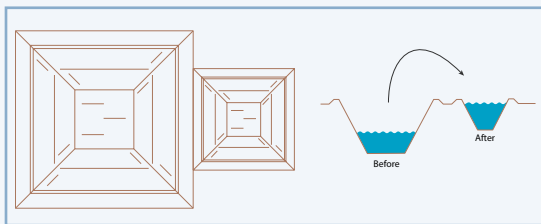

Figure 4. Double dams are useful where watertables limit depth.

### Gully-wall dams

Gully-wall dams are most common in the agricultural areas of the South West. Many horticulturalists rely on them to irrigate fruit and vegetable crops.

A designed spillway must be provided for gully-wall dams as they are normally built across a creek or drainage line (see Figure 5). The overflow water must return to the creek without changing the flow characteristics or causing erosion of the drainage line or damage to the dam wall.

If it is intended to site a gully-wall dam in a drainage line of a gazetted catchment, a licence is required from the Department of Environment. The Department also requires dams to be licensed if the wall is over 10 metres high or the capacity is to exceed 50,000 kilolitres (m<sup>3</sup>).

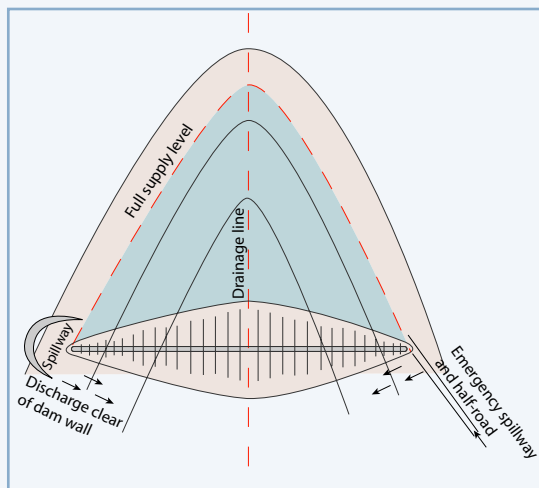

Figure 5. Plan of a gully-wall dam.

Gully-wall dams are only recommended where site investigation has shown there is no risk of salt intrusion from groundwater.

Gully-wall dams need an adequate system of spillways to manage flows generated from large rainfall events. The usual practice is to have the main spillway designed to manage a 1:20-year rainfall event and an emergency spillway for 1:50-year rainfall events or larger depending on the type of infrastructure located below the dam (see Figures 5 and 6).

### Detention dams

Landholders intending to develop environmental management systems (EMS) will need to incorporate detention dams into their farm plans to demonstrate they are managing surface water. The function of a detention dam is to store run-off from rainfall events that can be released over a longer period to reduce peak flows lower in the landscape that might result in flooding and inundation.

To be effective, detention dams need to have a capacity of at least 5,000 cubic metres and should be integrated where possible with other water supplies on the property. To manage the release of water from a detention dam it is important to have a large outlet pipe 150 to 200 mm in diameter. A manifold can be used to release water safely into a grassed waterway or drainage line.

### Flat batter dams

A flat batter dam is constructed with the dam and catchment as a single unit. This structure can be sited high in the landscape, which provides real benefits for reticulation of water and keeps the dam away from saline watertables. Flat batter dams do not require a large catchment and provide high quality water.

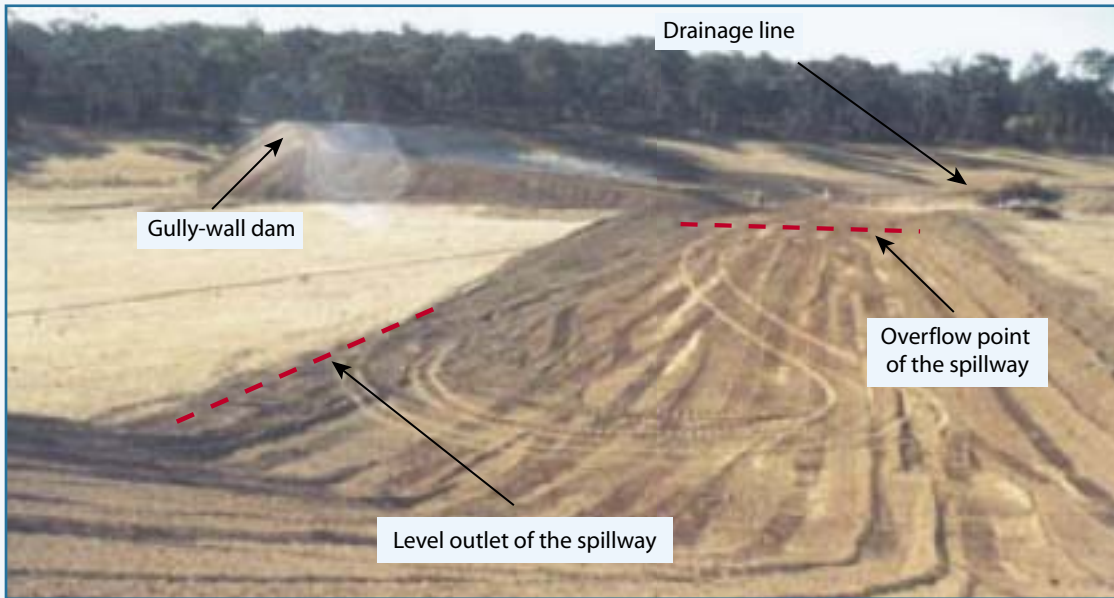

Figure 6. Spillway of a gully-wall dam east of Kojonup.

The dam can be constructed in deep sandy soils where a conventional dam would receive little or no run-off from the natural catchment, and where it is not economic to build roaded catchment due to excessive depth to clay. The circular flat batter dam is more cost-effective than the square dam and is cheaper and easier to maintain. The batters are almost flat 'saucer-like' structures and can have a slope of from 70:1 to 100:1, depending on the quality of clay used.

The batter forms a catchment surrounding the excavation; run-off enters the dam through inlet pipes and very little water is lost in transmission, which can affect other dams relying on natural catchment. The inlet pipes may be closed off and water from the catchment pumped into the dam to fully utilise the area around the excavation.

### Turkey nest and ring tanks

Turkey nest dams consist of a completely enclosed earth embankment, which is filled by pumping from an alternative water source (i.e. a creek, groundwater or other smaller dams). These dams are usually sited as high as possible in the landscape so that water can be reticulated from them to other parts of the property.

The dams built in WA do not usually retain a mound of soil in the centre and are smaller than those in New South Wales and Queensland (see Figure 7). Turkey nest dams require a site that is reasonably flat with good dam building clay that is not more than a metre below the ground, otherwise the cost of overburden removal reduces the cost effectiveness of construction.

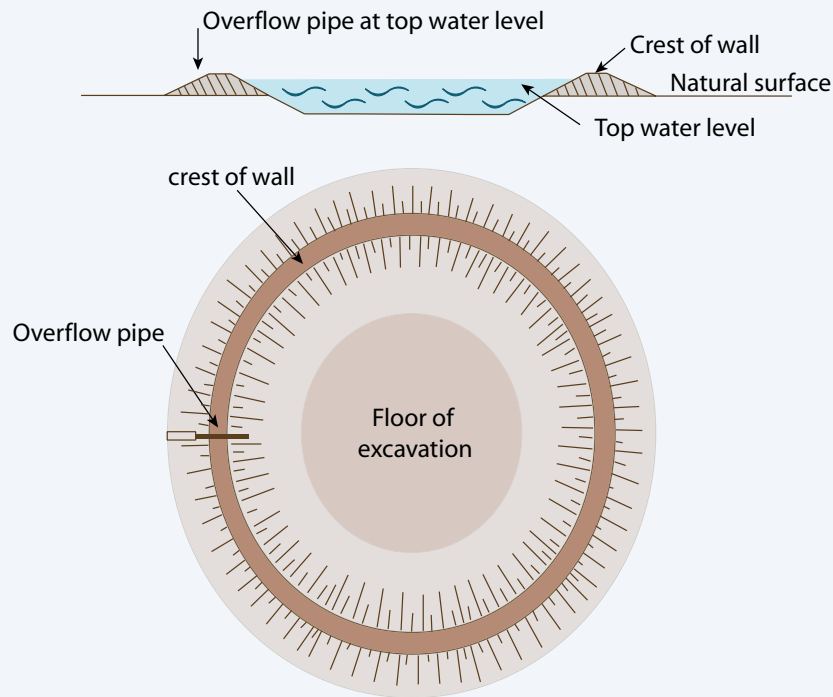

Figure 7. Turkey nest dam, shown in plan and cross-section.

### Soaks

Excavating earth tanks to take advantage of natural fresh water seeps is common. These dams usually rely on small semi-confined aquifers, perched watertables or hillside seeps. Where sites are available it is worth checking the water quality before building the dam. Particular care needs to be taken to seal soak dams.

### Planning considerations

Local government in WA has the authority to manage the development of agricultural land. Dams should be sited at least 200 to 250 metres (depending on slopes) from roads to ensure that they do not impact on the road foundation. This distance also allows overflow from dam spillways to return to normal flow patterns of the drainage lines before water crosses the road.

For dams sited below roads the best practice is to survey the area to ensure that a proposed dam will not interfere with roads. In agricultural landscapes, select sites for dams in mid-slopes, staying above valley floors to reduce the probability of failure due to rising saline groundwater.

Siting dams in valley floors or drainage lines should be avoided if shallow watertables are present.

Dams in drainage lines are prone to sedimentation and collect plant and animal residue transported by run-off from intense rainfall events. The failure rate resulting from a breach of the back wall is more common due to large flows being impounded beyond the design capacity.

To avoid these problems, dams should be sited to one side of drainage lines. Aerial photography provides an easy method of determining the size and quality of the catchment available. If necessary, flow can be diverted from the drainage line to the dam provided the spillway returns the overflow to that same drainage line before it leaves the property.

By selecting a dam site on sloping ground away from main drainage lines it is possible to obtain a favourable storage ratio, that is, more water stored than cubic metres of soil excavated. For example, a favourable storage to excavation ratio is obtained from a 4,500 cubic metre excavation that has capacity to hold 6,000 cubic metres of water.

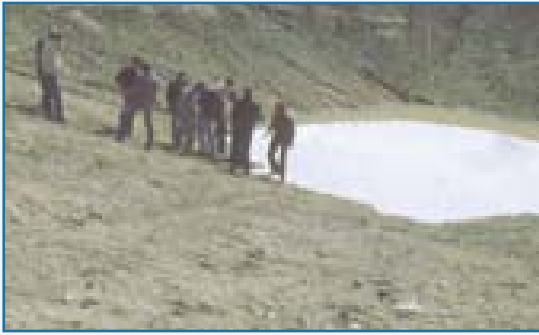

Light land dam at Bonnie Rock.

### Proposed dam sites

A number of issues need to be considered including:

- the proposed site should provide a favourable storage to excavation ratio making the farm dam cost-effective;
- the catchment area (which may include roaded catchment) must be large enough to allow the dam to maintain a reliable water supply relative to demand and evaporation loss;
- the spillway needs to manage flows from both the natural and improved catchment;
- catchment condition which will determine the quality of the water supply;
- minimising evaporation loss from prevailing winds; and
- adequate geotechnical information to minimise seepage losses and ensure stability of the dam.

Siting a detention dam at the head of a gully to detain run-off from farmland will control water erosion from intense rainfall events. Outlet pipes from detention dams (with drop inlets for large volumes of water) are designed to release flows over a longer period below the gully head combating water erosion. This enables the gully to be repaired and stabilised.

Farm dams should be constructed in clay soils with low permeability to minimise leakage. The range of sites across the State is highly variable. For example, dams can be successfully constructed with rock or hardpan bases in light land in the north-eastern wheatbelt, however site selection is critical.

TABLE 1 Livestock drinking rates

Animal	Type	Dry sheep equivalent	Litres of water per head per day
Sheep	Wethers and dry ewes	1	7
	Ewes with lambs	1.3	9
Cattle	Beef	10	45
	Dairy cow	15	70
	Bulls	15	Up to 90
Pigs	Sows	3.5	25
	Other pigs	2	10 to 15
Goats		2	14
Horses		10	45
Poultry	Laying hens		35L/100 birds*

\*(less is required with access to automatic drinkers)

Soil stabilisers are available that can be used to seal the catchment surface. These treatments can lower the threshold by reducing the permeability of the surface. Relying on compaction alone to improve catchment efficiency may not be adequate when the full impact of climate change further reduces the reliability of rainfall.

### Networking dams and other water supplies

It is very common for farms to have some paddocks where reliable dam sites are available and others where the soil type or presence of shallow watertables makes them less reliable. To optimise grazing efficiency of all paddocks it makes good sense to move water around the property. A common

technique is to build a turkey nest dam on a high point that is filled from dams with efficient catchments lower in the landscape. Water from the turkey nest can then be piped to less reliable dams or troughs.

### Determining demand for water

The demand for drinking water from various classes of livestock (see Table 1) will vary with:

- pasture type (e.g. stock on saltbush require good quality water and often drink 50% more than similar stock on normal pasture);
- the distance stock have to travel; and
- their type and condition.

Damcat is a software package developed by and available from the Department of Agriculture to assist in calculating dam size and catchment area for a required volume of stored water for an agreed number of dry sheep equivalents (DSE). This term is based on a 45 kg non-lactating sheep in forward store condition during summer, on a maintenance diet of clover or medic-based pasture. Damcat has proved a valuable tool in improving the reliability of farm water supplies. Generally farm dams are designed for a 22-month period without normal inflow, while key dams are designed to maintain supplies for 27-months.

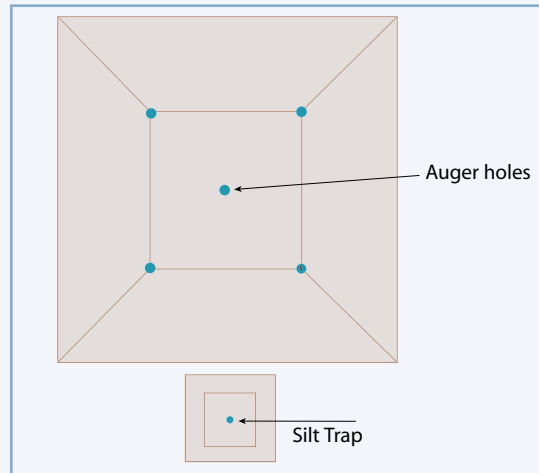

Figure 8. A minimum of five auger holes is required for a proposed site for a three or four-walled farm dam.

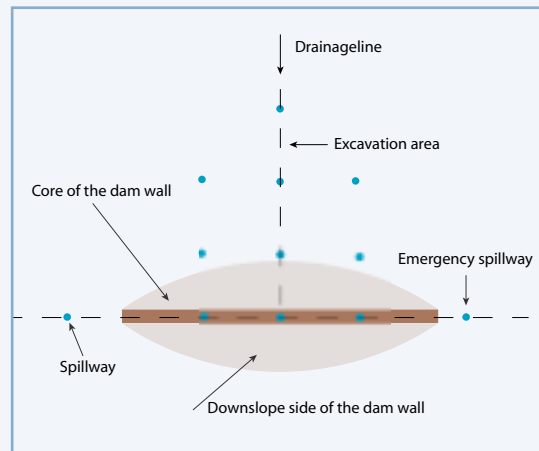

Figure 9. A minimum of nine auger holes is required for a proposed site for a gully-wall dam.

### Dam site selection

While native vegetation is a good indicator of soil type, investigation for dam site selection needs to include drilling at least five holes, one at each corner and one in the centre of the proposed site (see Figure 8). The test holes are drilled to at least 1 m below the proposed depth of the dam, to determine if shallow watertables are present and that the soil has satisfactory water-holding capability under the base of the dam.

The proposed site should be well clear of rising groundwater that could affect it in the future. Test holes should be drilled at least three days before construction commences to allow for monitoring. Drilling will also provide soil samples for geotechnical analysis of each metre of depth. This analysis will assist in determining the water-holding capacity of the clay.

Investigations need to determine if the catchment is large enough to yield sufficient water to maintain anticipated stock numbers on a year-round basis, or if improved catchment is required. If the dam is likely to need roaded catchment then site evaluation needs to be done at the same time. Excess water or overflow can also be taken to existing waterways or other dams by half-roads or graded banks.

### Testing the soil material

The soils from a proposed dam site need to be tested and the number of auger holes will depend on the design, size and type of structure. A traditional farm dam with three or four sides will require a minimum of five test holes, while a gully-wall dam will require at least nine test holes and often up to 11 (see Figures 8 and 9).

Soil samples are tested for water-holding capacity by:

- Hand-texturing for clay content

Soil texture indicates the proportions of clay, sand and silt. Hand-texturing (see Figure 10) will indicate clay content of a soil and its water-holding characteristics. For good water-holding capacity the clay content needs to be at least 35%.

- Hand-moulding for strength

The clay must be capable of being worked like plasticine to form a ribbon of 75 mm or more (see Figure 11).

Soil properties that favour good water-holding capacity of farm dams are:

- high clay content;
- high exchangeable sodium and magnesium; and
- strong soil structure.

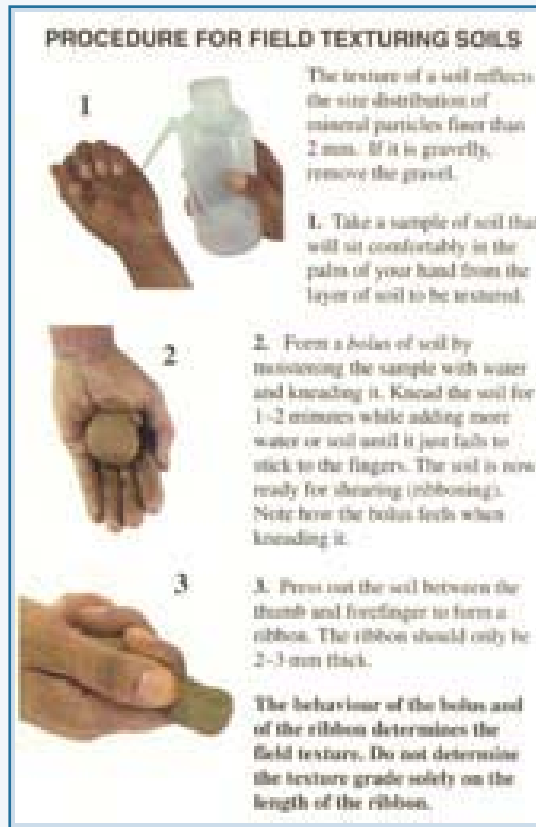

Figure 10. Hand texturing soils.

When the results from the test holes have confirmed that the site is likely to be successful, the next step is to dig at least two backhoe pits. These pits will provide access to soil that has not been mixed and highlight possible problems such as sand seams.

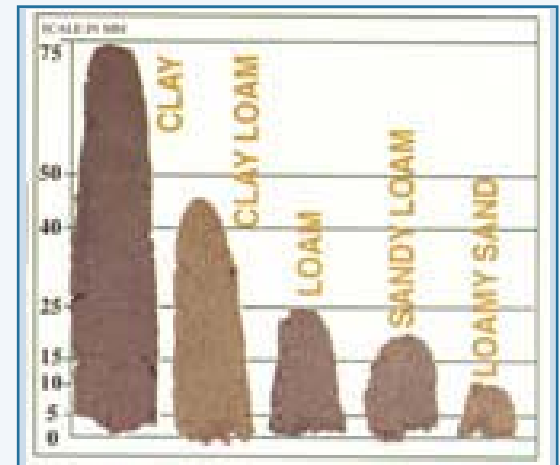

Figure 11. Hand moulding for strength.

### Quotations from earthmoving contractors

Not all earthmoving contractors have the experience or ability to build dams to an acceptable standard. Look at some recent work by the contractor you are considering and be prepared to discuss it with other customers. Landholders should always ask for an itemised quotation for any type of farm water supply.

This allows realistic comparison between different contractors and indicates the likely quality of construction at the end.

## Quotation checklist

### Dam site selection and survey

- Test drilling as illustrated in Figures 8 and 9;
- Soil testing to determine water-holding capacity;
- Preparation of a plan and cross-section view as illustrated in Figure 7. These plans need to show specifications and include an estimation of the capacity and total volume of excavation that the landholder is expected to pay for.

### Construction

- Site preparation;
- Stockpiling of overburden;
- Core key dam walls into impervious material;
- Installation of inlet and outlet pipes;
- Description of earthmoving machinery that will be used:
  - bulldozer
  - scraper
  - road grader
  - roller;

- Commencement date for construction;
- Agreed responsibilities, e.g. the landholder may be responsible for providing the inlet and outlet pipes;
- Topsoiling of the external dam batters;
- Gravel layer from the top of the dam down to full supply level to prevent rip-rap damage.
- Total cost and likely completion date.

## Dam failures and problems

### Breach of a dam wall

When a dam wall breaches, particularly a gully-wall dam, it releases a large volume of water and can cause severe damage to property, roads and other farm infrastructure.

Sites where the soil has a low clay content make it more difficult to design and construct a wall that has a good seal and therefore low seepage losses. Usually these weak clays cause piping failure and such sites should be avoided.

It is recommended that the dam be fenced to keep out stock, and a pump and trough system installed to allow livestock access to the water. Fencing will minimise damage to batter slopes and fringing

vegetation, and control sheep access points that can lead to erosion.

### Evaporation and seepage losses

Evaporation losses are an important consideration in selecting the dam type and site. Design choice is important as the exposed surface area relative to depth (e.g. square, rectangular or circular) will determine the rate of evaporation. A circular dam has the smallest surface area and lower losses than other shapes with the same storage capacity and depth.

Evaporation can be further reduced by planting windbreaks. These need to be far enough from the dam so the roots do not interfere with its integrity, but close enough to reduce the wind. Windbreaks also need to be positioned at right angles to prevailing winds and large enough to ensure that they do not increase wind speeds near the dam. Seepage always occurs, however, it is only when these losses exceed 1.5 millimetres per day that it is considered a problem.

With large dams, seepage through the walls needs to be managed. The usual technique is to place overburden on the toe of the dam wall to provide a filter during the preparation phase. With gully-wall dams, it is often necessary to construct a filter to dry out the toe of the dam wall.

A four-walled or circular dam should include wing banks and a silt or sediment trap to provide temporary storage in front of the dam. A piped inlet should be installed to convey the water safely to the bottom of the dam, reducing erosion and preventing sedimentation. Constructing a silt trap will reduce time spent on maintenance and improve long-term reliability.

## Design of a conventional excavated tank

### Spillways

Dams require a spillway that will direct overflow into a safe disposal area (e.g. grassed waterway or creek system) to reduce the potential for erosion. Spillways should be designed to ensure that sufficient freeboard is available to prevent the dam from over-topping under adverse conditions such as peak flow events and maximum wave action.

Freeboard is the vertical distance between the floor of the spillway and the top of the dam. Normally the freeboard of small dams (largest length of water less than 600 m) is 1 m, and increases with size. To achieve a freeboard of 1 m, an allowance is needed for settlement.

The spillway outlet should always be level to ensure that the dam can overflow to its designed capacity when necessary. Dams should be equipped with

an emergency spillway (a broad vegetated channel designed to discharge flow in excess of the main spillway) designed for a longer return period, usually a 1:50-year ARI (average recurrence interval). If expensive infrastructure lies below the dam the capacity of the emergency spillway should be increased to manage a 1:100-year ARI. (Average recurrence interval is the average period in years between a rainfall event of specified magnitude and an equal or greater rainfall event.)

The spillway consists of four elements:

- approach channel;
- exit channel;
- grassed spillway; and
- spillway (see Figures 12 and 13).

A spillway requires a level section with a minimum length of 8 m and cross-sectional area calculated from the formula:

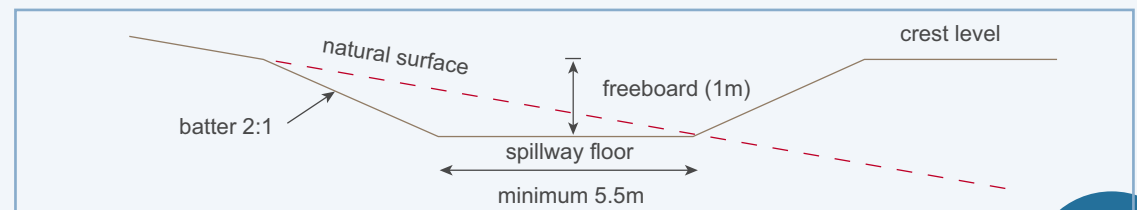

Figure 13. Cross-section of a spillway.

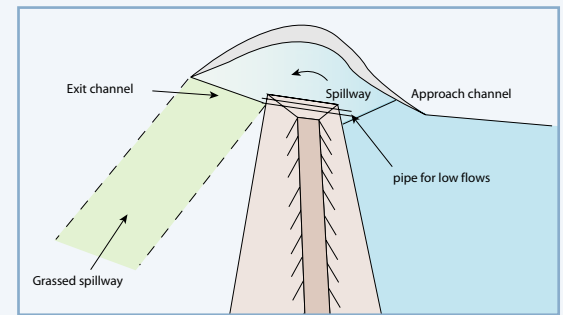

Figure 12. Spillway layout for a gully-wall dam.

$$Q = 1.7W \times H^{1.5}$$

where  $Q = 1:20, 1:50$  or  $1:100$ -year peak discharge ( $m^3/s$ )

$W =$  spillway width (m)

$H =$  surcharge depth of flood in spillway (m).

\* For grassed spillways a constant of 1.546 can be used instead of 1.7, which is used for rock and bare earth.

The spillway batters should be no steeper than 2:1.

The spillway should discharge into a grassed waterway or other safe and stable disposal point.

### Top width of dam wall

On small dams, the width of the wall at the top will necessarily be greater than the width of the bulldozer blade. As a rule, the minimum top width should be calculated using the formula:

$$W = 0.4H + 1$$

where  $W =$  top width in metres

$H =$  maximum height of embankment in metres.

For a dam wall with a height above ground of 6m:

$$W = 0.4 \times 6 + 1$$

$$W = 3.4 \text{ m}$$

The top of the wall should have a slight grade towards the inside of the dam to reduce

the amount of water running down the outside batter.

### Calculations for three- or four-sided excavated tanks

The landholder is quoted on the number of cubic metres that have been excavated.

The excavated volume equals the capacity of the dam. To calculate the capacity of the dam:

$$V_c = D \left( \frac{A_1 + 4am + A_2}{6} \right)$$

where:

- $V_c =$  capacity of the dam in cubic metres
- $D =$  depth
- $A_1 =$  area of the top ( $L \times W$ )
- $am =$  area of the mean
- $A_2 =$  Area of the bottom ( $l \times w$ )

To calculate the volume of the wedge:

$$V_w = hW \left( \frac{3L - 2Xh}{6} \right)$$

where:

- $V_w =$  volume of the wedge ( $m^3$ )
- $h =$  height above ground (m)
- $W =$  width (m)
- $L =$  length of top (m)
- $X =$  batter slope (m)
- $X = \frac{L-l}{D}$

where:

- $l =$  length of bottom (m)
- $D =$  depth (m)

at full supply level less the volume of the wedge that results from the slope on the original ground surface

Therefore, the volume of the excavation is the capacity less the volume of the wedge.

$$V_e = V_c - V_w$$

Spring is the best time to build most farm dams in WA agricultural areas when soil moisture is at an optimum level for efficient earthmoving and compaction of walls. Construction requires a bulldozer, and depending on size, a scraper and road grader may also be used to achieve the best results. Because of the cost of mobilising earthmoving machinery, most landholders build with only a bulldozer, but this does not produce the best compaction.

## Construction

### Site preparation

The proposed site must be resurveyed with site pegs and marked out before construction starts. These pegs should be left in place to assist the operator to maintain the original design. Some operators will keep pegs within the dam as a guide during



*First floor exposed and ready for ripping.*

construction. If more than one machine is working at the same time, site pegs help improve efficiency.

### **Removal of overburden**

The removal of overburden is essential as this soil usually contains inadequate clay to hold water.

Overburden should be stockpiled around the site and used to topsoil the external walls to reduce erosion of the batters and improve the stability of the structure.

### **Keying-in the dam wall**

The walls must be keyed-in or attached to the underlying soil to reduce seepage loss. As each dam site is different, the method is generally site-specific. When dam walls are not keyed into impervious soil effectively, it will severely reduce the depth of water held even if the dam does not fail.



*Farm dam with a wing bank and inlet pipes.*

The clay subsoil from the excavation is placed on three sides of the square or rectangular dam.

The clay core will greatly reduce seepage loss (an outlet pipe with anti-seep collars should be installed at this stage on large dams). The upslope side is constructed to allow safe entry of run-off from the catchment into the dam with a trap placed in front to manage the entry of water and capture sediment.

### **Layering material and compaction**

With scraper-built dams, moving material from the excavation onto the dam walls is a staged process of emptying the bowl of the scraper over a reasonable distance. With bulldozer-built dams, it is important that the bulldozer moves onto the top of the wall at

regular intervals and distributes the material in a thin layer to ensure satisfactory mixing and compaction.

Compaction using a roller during construction is critical for earth dams. Compaction of loose soils increases their unit weight, resulting in increased shear strength and decreased hydraulic conductivity. For a wall to hold water above ground level it needs sufficient strength to minimise seepage. Provided the soil moisture is adequate, a rubber-tyred or sheeps



*Sheeps-foot roller*

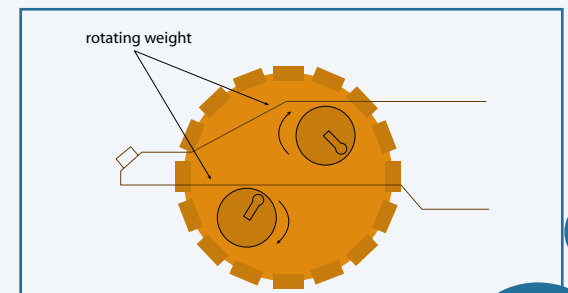

*Figure 14. Diagram of a sheeps-foot roller.*

foot roller can be used to compact the soil to reduce the potential for leakage (see Figure 14).

### *Inlet pipes with wing banks*

Farm dams in agricultural areas are usually excavated tanks with batter slopes of 1:3 to minimise water loss from evaporation, while not being too steep to allow stock to enter and exit safely.

They rarely have any special provision for inflow. As a result, erosion of inlet batters causes sedimentation that reduces the storage life. Pipe inlets can prevent erosion of inlet batters by allowing water to be conveyed safely into the dam. They also reduce sedimentation, as the water ponds, allowing time for some of the sediment load to settle.

Pipe inlets are constructed as part of a fully enclosed dam with all walls raised above ground level.

Wing banks are extended from the front wall of the dam to form a shallow temporary storage. Pipes run through the front wall to conduct water from the temporary storage to a safe delivery point in the dam.

Design of the pipe inlet needs to prevent overflow from temporary

storage before the dam is filled. To achieve this, the capacity of the pipes and the size of the temporary storage need to be designed with consideration for the catchment characteristics. Calculations of this type are very site-specific and individual analysis is not justified except on very large projects (i.e. dam volumes greater than 7,500 cubic metres).

### *Design guidelines for inlet pipes*

The design outlined below has been shown to be reliable and cost-effective. Run-off from small areas of roaded or artificial catchment is more predictable and manageable than from large natural or farmland catchments. As a result, the capital cost of a piped inlet for a roaded or artificial catchment will be much less.

Dams with roaded or improved catchments and less than 25 ha of farmland catchment:

- Minimum temporary storage of 1000 m<sup>3</sup>;
- Minimum of 250 m<sup>3</sup> of temporary storage for each hectare of roaded or improved catchment;
- Minimum of three 100 mm poly (black) or PVC (class 12) inlet pipes or two 150 mm poly (black) or PVC (class 12 minimum specification) inlet pipes;
- Minimum of one 100 mm poly or PVC inlet pipe per hectare of roaded/artificial catchment or 0.4

runs of 150 mm poly or PVC pipe per hectare of roaded or improved catchment.

Dams with natural or improved farmland catchments greater than 25 ha:

- Minimum temporary storage volume of 800 to 1000 m<sup>3</sup>;
- Minimum of three 150 mm poly or PVC inlet pipes.

Poly pipe is recommended for inlet pipes as it is relatively inexpensive, unaffected by corrosion or direct sunlight, and is light and flexible.

The earthmoving costs associated with construction of the wing banks for temporary storage will increase with size. The channel depth of wing banks should not exceed 250 mm. This is because excavation below ground level in front of the dam reduces the effective depth of water in the dam. The solution is to build wing banks using spoil from the dam construction.

Inlet pipes are installed while construction is in progress. During site preparation, after the first floor has been excavated, a trench (usually a blade width wide) is pushed from the inlet point to the exit point inside the dam. Pipes are placed in the trench and a front-end loader used to compact around them. Seepage collars made of cement are used to provide

a seal to prevent water seeping along the outside surface of the pipes. Using a front-end loader to fill the trench and starting at the inside of the dam the pipes can be well compacted in place. With cover to a depth of 300 mm, the bulldozer can be used for compaction. If the pipes are installed above ground level at the inlet point, ponding will result and valuable water can be lost.

The wing banks are surveyed with a grade between 0.25% and 0.5%. The vertical height of the ends in relation to the inlet determines the height and volume of water held in the temporary storage. Dam spillways need to be incorporated into the wing banks to provide adequate freeboard for the dam. The recommended freeboard is 1 m for dam walls and 0.3 m for wing banks when the core of the dam is being constructed. This allows for the reinstated soil material around the pipe to be properly compacted through the base of the dam wall.

### **Outlet pipes**

The use of an outlet pipe through the back wall of a dam to distribute water to tanks and troughs or dams in other paddocks is often overlooked. The main reason is the installation needs to be supervised by an experienced person as the integrity of the dam wall can be threatened by seepage loss along the pipe.

An outlet pipe should be installed when the dam core is being constructed. This allows for the reinstated soil material around it to be properly compacted through the base of the dam wall.

The outlet pipe should be sewer quality PVC or heavy black poly pipe so that it is not damaged during construction or from water hammer when used. Outlet pipes need a minimum diameter of 150 mm and if the dam is for horticulture it may need to be 200 mm or larger depending on demand.

A trench needs to be prepared for installation of the pipe that is wide enough to accommodate a front-end loader. The trench should be level or have a slight grade towards the outside of the dam. The pipe is laid in the centre of the trench, then to secure it and reduce the likelihood of seepage, concrete collars are placed around it. The position and number of collars need to be determined on-site. Generally a collar will be placed at the ends of the pipe, at the core and then at regular intervals along its length. Using clay stockpiled by a bulldozer, a front-end loader is used to place clay in the trench and provide compaction. Compaction around the pipe will have to be done by hand to provide a tight seal. Site pegs are then located and the pipe capped so that it can be relocated when the

wall construction is complete. After the construction is complete the pipe can be extended. To prevent blockages it is usual practice to use a manifold covered with gauze on the inlet. Floating inlets are generally trouble-free and much easier to service.

### **Levels and measurements**

During construction, the contractor should take appropriate measurements to ensure that the wall is level, the batter slopes are correct and that compaction is adequate.



*Checking for low points.*

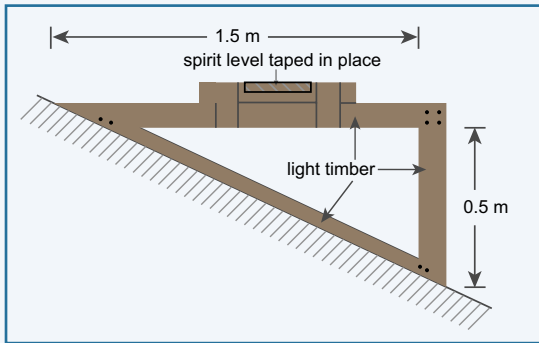

Figure 15. A batter board is very useful to ensure that batters are kept to specification. Batters that are too steep create problems for stock and maintenance of the dam.

### Top height and width of the dam wall

It is always better for the top width of the dam to exceed the design requirements as a safety measure. In some cases, particularly on slopes with a low gradient, there is little point in extending the wall height greater than the required freeboard as this is costly for the contractor.

### Batter slopes

The batter slopes should be flat enough to allow livestock safe entry and exit. As a general rule, most farm dams are constructed with 3:1 batters on the inside and slightly steeper (2 - 2.5:1) on the outside. Where the material is not compacted, the batter slopes should be flatter than 3:1 or stability can be a problem. Batter slopes can be easily checked with a batter board (see Figure 15). Where rilling of batters is likely to be a problem, side-cutting can be effective as a final operation in eliminating track marks left by the bulldozer.

### Topsoiling

Topsoiling is recommended to help stabilise external dam walls. Over time, walls that have not been protected by topsoil often require more maintenance. Topsoiling encourages growth of vegetation, reducing erosion.

### Filling the dam

Once construction is completed, the dam should be filled slowly and monitored carefully to ensure that it holds water. If heavy rainfall events follow construction of excavated tanks equipped with inlet pipes, the rate of fill can be reduced by blocking them. This allows the dam walls to wet up evenly.

In a similar situation with gully-wall dams it is recommended to leave the outlet pipe open to increase the time taken for the dam to fill and allow the dam wall to wet up evenly.

### Rip-rap

Wave action on large dams can cause serious and costly damage to the batters. Rip-rap is loose rock, stone or coarse gravel compacted onto the batter surface to protect it from wave action.

When such damage is not repaired it can result in a breach of the dam wall. Compacted gravel is the easiest rip-rap material to use.

## **Maintenance**

---

Embankments should be inspected regularly for signs of cracking, piping, settlement, subsidence and other problems (such as animal burrowing). Poor materials, weak foundations, and low-standard design and construction are usually the cause of embankment failure and erosion.

Pollution of dams is often caused by inflow of dry pasture, sheep manure and straw during large storms. Preventing such material entering the dam can be achieved with rabbit-netting across the front. Fencing to provide a permanently grassed area in front of the dam will provide a grass filter.

Construction of a silt trap in the front of the dam, in which material can be collected, will also reduce maintenance. Silt traps should be cleaned out regularly with a front-end loader. This is usually carried out in late summer as the dam needs to be drained and allowed to dry out. Then, using two tractors and a scoop, the sediment can be removed. In some situations it is easier to use a large loader or bulldozer.

It is also practical to pump sediment from a dam when it is full using a submersible sludge pump. It is usual practice to use two tractors with cables to position the pump in the dam. For a gully-wall dam it is often necessary to use a drag-line or excavator.

## **Legal aspects**

---

Landholders need to consider a number of legal issues before commencing to build a dam. The following is an overview of common issues. For more detailed information, seek appropriate professional advice.

### **Planning approval**

Construction of a dam may require development approval from the relevant local government authority. Requirements for approval vary from district to district, so contact the local shire to see what rules apply. Failure to obtain approval when required to do so is an offence which can cause fines of up to \$50,000, as well as orders to remove the offending works.

### **Earthworks on watercourses, wetlands**

In some parts of the State, approval is required to construct a dam across a watercourse or wetland. Many watercourses in the South West are subject to these controls. Before constructing a dam on a watercourse or wetland, contact the Department of Environment to see whether a permit is required.

### **Licence to take water**

In addition to requiring a permit to build a dam on a watercourse of wetland, a licence may be needed to take water from that dam once it is operational. This would apply to many dams which are built on, or divert water from watercourses, and dams which intercept groundwater as wells. Again, these rules do not apply everywhere. Contact the Department of Environment to see what rules apply to your dam.

### **Protection of native vegetation**

If construction or operation of a dam requires, or leads to the removal of native vegetation, it is likely a clearing permit will be needed. For information on permits and possible exemptions, contact the Department of Environment.

### **Duty to take care**

Under common law, landholders have a duty to ensure that the use and enjoyment of the land does not unreasonably interfere with neighbours' use and enjoyment of their land. They also have a duty to avoid acting negligently or recklessly in circumstances where damage could result to other persons or to property.

As dam failures have potential to cause significant damage to downstream landholders, special care needs to be exercised in identifying a suitable dam site, constructing the dam and providing ongoing maintenance. If a dam fails and causes losses to others significant damages claims could result. Landholders can minimise this risk by seeking professional advice before commencing work, especially in circumstances where the failure of the dam may cause significant damage (due to its size or proximity to downstream infrastructure such as roads and buildings).

For further advice on liability issues relating to dam construction and operation, consult a legal practitioner.

### ***Impacts and risks***

---

Erosion of dam batters may occur due to run-off, especially when the dam is new. This can be reduced by placing topsoil over the batters and using double the normal seeding rates of pasture grasses. The downslope batter should be seeded with a mixture of clovers, annual ryegrass and oats. On the upslope batter is it often possible to establish kikuyu grass from runners or seed.

Planting trees near a dam can cause leakage, but if placed a correct distance from the base of the dam wall, trees can be used as a windbreak to reduce evaporation losses. Normally tree roots cover an area 150% greater than the canopy. It is important that the windbreak extends well beyond the perimeter of the dam otherwise it will increase wind speeds across the water.

Farm dams should not be sited closer than 300 m from boundary fences without agreement from the adjoining land user.

It has also been shown that where farm dams have been sited to use roads as catchment they can cause inundation and waterlogging of the road formation.

When maximising the extent of the catchment available to the dam, care should be taken not to bring water from another catchment as this is a breach of riparian law.

## Glossary

---

Clay	<i>Soil material consisting of mineral particles less than 0.002 mm in diameter. Many physical and chemical properties of soil depend on the quantity of clay it contains.</i>
Compaction	The densification of soil by removal of air, usually achieved by rolling. Optimum compaction depends on moisture content of the soil.
Collar	An anti-seep colla