



## STORED GRAIN MANAGEMENT

Reviewed July 2005

# Grain storage: Design and installation

*By Ed Blanchard, Agricultural Engineer, formerly Dryland Research Institute, Merredin and Chris Newman, Technical Officer, Department of Agriculture, Forrestfield*

Growers store an average of 200 tonnes (t) of grains per farm, according to surveys. Based on \$200/t, this means an average investment of \$40,000 each.

Whether this grain is to be fed to livestock or to be sold later in the year, this investment must be protected.

Problems with stored grain have been reported from all parts of the agricultural area. Problems include caking on silo walls, damp mouldy grain in the base of the store and sprouting grain in the headspace. These are caused by poor grain management or poor maintenance of the grain store.

Other problems have been reported with lupins or peas stored in old silos. Walls have buckled or compressed from the greater pressure exerted by the round seeds, and in extreme cases the silo has collapsed. All these problems result in loss of all or part of a grower's investment. To prevent this loss the silo must be managed correctly from the time it is erected on the property.

## Silo installation

Many problems result from incorrect preparation of the silo base pad. Silos have been mounted on plough discs, sleepers, poor quality concrete, non-reinforced concrete or even directly on the ground. Nearly all silo manufacturers have experienced this problem on occasions. Incorrect mounting sometimes results in total collapse of the silo.

Elevated silos are a fully stressed structure, engineered to support grain in a vertical plane with pressure exerted and distributed evenly around the base support frame. If the pad is not level, the weight of the grain will be transferred to the low side of the silo. This will place excessive stresses on the lower sheets of the silo.

An uneven pad also increases the pressure in one area, twisting the base frame and deforming the silo. The effects may not be seen for some time, probably not until extra stress is placed on the silo wall by storing products such as peas or lupins with higher bulk density. This localised force may burst seams, causing the silo to collapse.

## Elevated silo pad

The most important step in establishing a silo is to construct a good quality pad.

The following description of a simple universal silo pad is designed to suit most situations. Before using this design you should contact the manufacturer to ensure this type of pad construction will not affect the silo warranty.

On a difficult site you should engage a consulting engineer.

The concrete pad should extend completely under the silo to assist in maintaining farm hygiene around the storage complex. This is a major factor in controlling insect pests. The pad should also extend at least 300 mm beyond the silo base to prevent run-off from the roof of the silo undermining the concrete pad. The pad must be constructed level and be as flat as possible.

When concrete is mixed on-site it should consist of a mix of one part cement, two parts sand, and three parts aggregate (blue metal) of minimum size 20 mm diameter. If metal dust is used, mix one part cement, one part sand and three parts of metal dust. The strength of concrete depends on the cement/water ratio. Add only enough water so that the mix can be placed and not poured. If delivered ready-mixed, it should meet the Australian Standard which is a strength of 20 MPa.

Choose a site to erect the silos that is stable and level with no chance of erosion from run-off. Take care to avoid soft soils and clays that expand when wetted. Clear vegetation from an area one metre larger than the pad. Grade it 100 mm below ground level to provide a level area for the slab and adequate drainage away from the pad edges. A layer 30-50 mm deep of well draining material (sand or metal dust) should be placed on the base and compacted by watering and rolling. Alternatively, on a clay soil place a plastic ground sheet over the compacted soil to help prevent drying and cracking of the subsoil.

## Important Disclaimer

*The Chief Executive Officer of the Department of Agriculture and the State of Western Australia accept no liability whatsoever by reason of negligence or otherwise arising from the use or release of this information or any part of it.*

Mark out a square pad 600 mm larger than the diameter of the proposed silo. Build a form 175 mm deep with adequate timbers and make sure they are level. Two layers of reinforcing mesh are needed to give the pad adequate strength; ARC 72 (200 mm x 200 mm square mesh x 7.1 mm rod size) should be used. Two sheets should be cut and placed (Figure 1).

Wire the mesh together to stop them moving when the concrete is poured. Put the first layer of mesh within the formwork supported on 40 mm wooden blocks or use 'bar chairs' (steel supports). Pour the first layer of concrete to 125 mm (5"), put in the second layer of mesh and complete the pour. Screed the concrete level with the top of the timbers. For silos larger than 2000 bushels, the slab should be 230 mm thick, and the concrete depth between the layers of mesh 175 mm.

Two types of holding down bolts may be used:

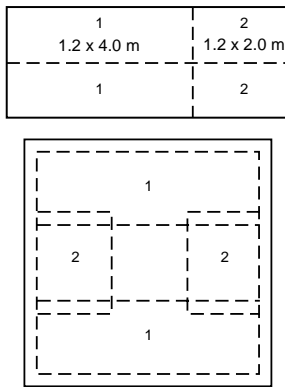

2 sheets mesh required  
Top and bottom same

Figure 1. Cutting and placing plans for reinforcing mesh required in a concrete silo pad.

- Set four 16 mm bolts in the concrete so the centre line of the bolts is just inside the silo base ring, and the bolts are sticking up about 75 mm. See Figure 2 to modify to a standard bolt.

- Use a masonry bolt that is put into a hole drilled after the silo is placed on the pad. Use four 12 or 16 mm bolts equally spaced around the silo base ring. The silo is held down using clamping brackets to suit the base ring design, normally a 'J' shape or pipe bracket

(Figure 3). Consult the manufacturer for exact positioning of bolts.

Allow the concrete pad to cure for at least seven days before loading the silo. Cover the pad with plastic to prevent drying during curing. Do not concrete the silo base ring into the concrete as it will corrode.

### Flat floor silos

Concrete-based silos are usually erected by contractors, but if you are building it yourself, the following instructions apply.

Lay a plastic sheet under the concrete to damp proof the silo and prevent spoilage in the lower grain layers. The concrete mix should be as described above. The

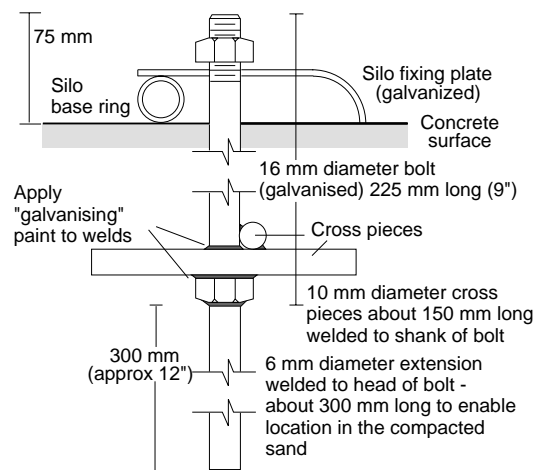

Figure 2. Modification of standard bolt for use

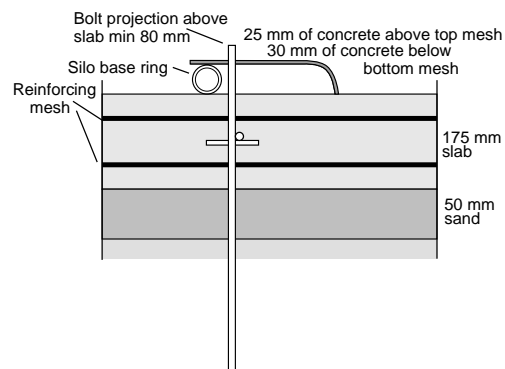

Figure 3. Slab section and holding down

thickness of the concrete and reinforcement should be according to the manufacturer's specifications. This depends on the capacity of the silo being constructed.

The steel walls must be kept separated from the concrete pad to prevent corrosion. Use a bituminous felt, rubber compound strip or a silicone product.

### Further reading

- Farmnote 24/02 'Aeration - for preserving grain quality'
- Farmnote 65/03 'Grain storage : Maintaining grain quality'
- Farmnotme 66/03 'Grain storage: Handling and maintenance'
- Farmnote 67/03 'Sealed silos make \$ense'
- Farmnote 68/03 'It makes \$ense to maintain your sealed silo'
- Farmnote 69/03 'Effective fumigation needs a properly sealed silo'
- Farmnote 70/03 "Underground storage of grain"